

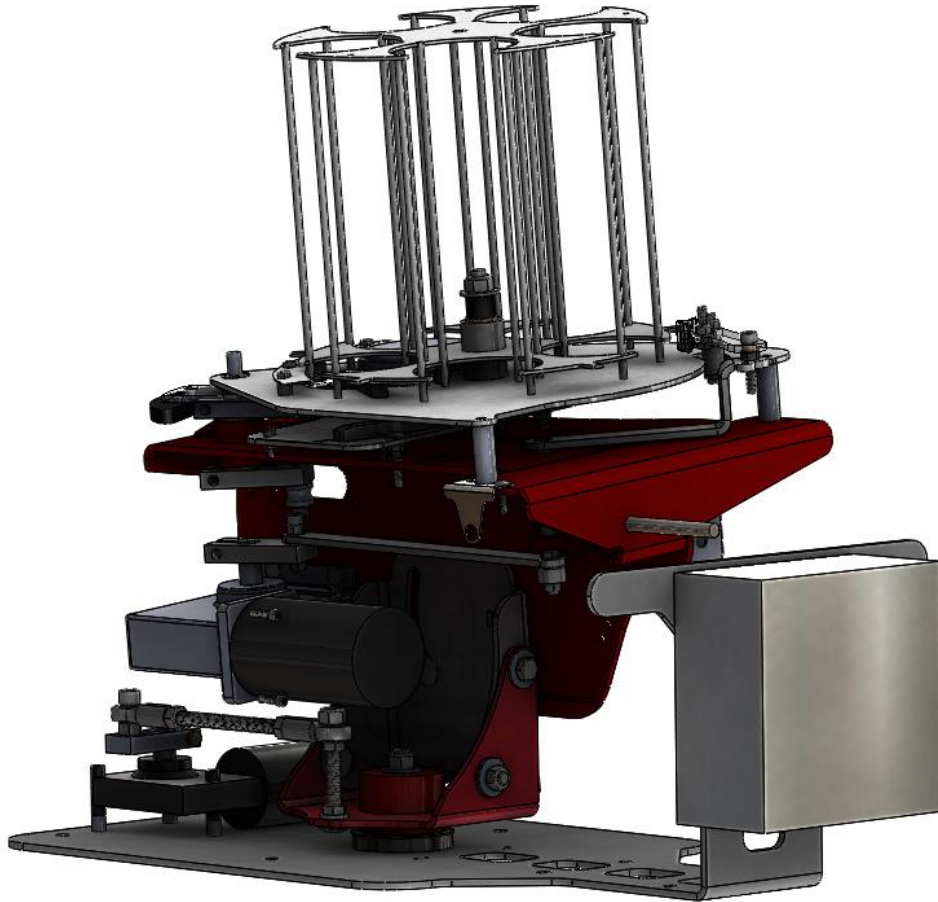

CLAY TARGET MACHINES

OWNERS MANUAL FOR MEC 100E ATA



PLEASE READ AND FULLY UNDERSTAND THE INSTRUCTIONS PRIOR TO SETTING OR TUNING THE MACHINE.

CAUTION: ANY MEC CLAY TARGET MACHINE MUST BE IN THE DISARMED STATE WITH THE BATTERY DISCONNECTED PRIOR TO MAKING ANY ADJUSTMENTS, LOADING THE CLAY TARGETS OR TRANSPORTATION OF MACHINE.

Step 1 – Securely set the machine in the trap house. See below for the correct way to install the MEC machine into the trap house. **IF NOT FASTENED SECURELY, SERIOUS INJURY AND/OR DAMAGE TO MACHINE CAN OCCUR!!!**

DO NOT CONNECT THE POWER. Ensure that the machine is in the **DISARMED/SAFE** position.



CLAY TARGET MACHINES

NOTE – In some instances your machine may be missing the top plate shaft. This was done purposely to allow us to ship more economically. You will have to do a few easy steps to reattach the shaft to the top plate.

Step 2 – Undo the 5/16" nuts that hold the top plate to the frame. Swing the pusher out of the way.



Step 3 – Swing the plate out towards the front of the machine. This will allow you access the holes in the top plate to attach the shaft. Using the 3 bolts provided simply tighten the shaft to the top plate. For added security Red Loktite can be used, but is not necessary.





CLAY TARGET MACHINES

Step 4 – Next, swing the plate back around and rest on the Nylon spacers. Reattach the 5/16” Carriage bolts and secure with the Lock Nuts. Lastly, place the carousel onto the shaft, followed by the gray plastic spacer, then the washer, and finally secure with the locknut. If no grease is present, please add a little bit to the shaft. You may have to spin/rotate the carousel counter clockwise for it to slide on. Next, place the gray plastic collar over the shaft and onto the flange bearing in the carousel. Now place the 3/4” washer and nut onto the threads and tighten. Do not over tighten. You want a little bit of resistance there, but not too much. You shouldn’t be able to spin the carousel with one finger.



Step 5 – Check the height / clearance of the knife-edges by placing a clay in the carousel. Rotate the carousel so that the clay starts to pass underneath the inner and outer knife separator blades. The clay must pass freely under the knife separator blades without binding but with the minimum of clearance. Adjust if necessary with 7/16” open ended wrench. You are looking for a gap about the thickness of a business card, between the horizontal shoulder of the clay and the underside of the knife edges. Photos below show adjustment with carousel fitted, but you can remove the carousel to make adjustment easier if preferred.

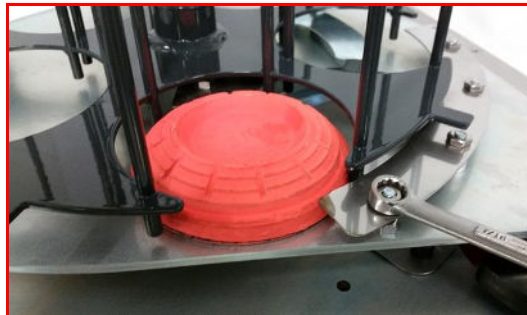
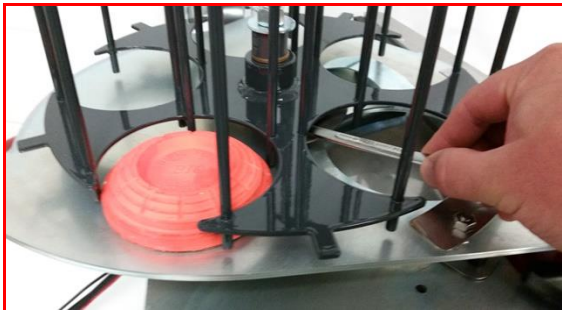

**** ALL MEC MACHINES ARE SET UP USING THE WHITE FLYER STANDARD TARGETS. ADJUSTMENTS NEED TO BE MADE WHEN USING OTHER BRANDS OR STYLES OF TARGETS****



CLAY TARGET MACHINES

UNDERSTANDING THE CONTROL BOX

ROTATION



DISARM
OFF
ARM

FIRE
BUTTON

REMOTE
DISARM
SOCKET



OSC.
BREAKER



MAIN
BREAKER



CLAY TARGET MACHINES

Rotation Toggle Switch – Pushing the switch downward will turn the oscillation motor on. Note that the oscillation motor will randomly start/stop when the machine is in operation. This prevents shooters from being able to predict the direction of the next target. Pushing the toggle switch upward allows you to nudge the oscillation motor which pivots the machine from one side to the other enabling you to check the angle of the clays flight.

Remote Disarm Socket – The remote disarm socket on the side of the control box allows the remote disarm box assembly and 10ft. of cable (not included) to plug in and then it can be placed by the opening of the trap house. This allows the user to disarm the machine before entering the trap house.

Fire Button – The fire button allows you to test fire the machine from inside the trap house.

Disarm/Off/Arm – Pushing the switch downward to the arm state will arm the machine. Pushing the switch upward will cause the machine to fire (if in armed state) and disarm when the switch is released. Note – holding the disarm toggle will continually fire clay targets. Please use caution!

Breakers – The breaker on the left is for the oscillation motor. The breaker on the right is for the cocking motor. If the breaker trips, it needs to be pushed back in to reset.

Step 6 – Check that the ARM/OFF/DISARM switch on the electrical box is in the **OFF** position.

Step 7 – Visually check, from the rear of the machine, that the motion of the Throwing Arm is not restricted or blocked in any way.

CAUTION: ALWAYS OPERATE THE MACHINE FROM BEHIND, NEVER FROM THE FRONT OR THE SIDES OF THE MACHINE. KEEP HANDS AND BODY PARTS AWAY FROM THE MACHINE WHEN ARMING, RELEASING AND DISARMING.

Step 8 – Standing at arm's length behind the machine and making sure that all body parts are clear of the machine, push the ARM/OFF/DISARM toggle switch into the DISARM position and then release it as soon as the throwing arm fires. The toggle switch is spring loaded and will return to the off position as soon as the switch is released, stopping the machine from re-arming itself. If done correctly the arm will be pointing away from the left side of the machine when viewed from behind.

Disconnect the power supply to ensure that the machine is not accidentally armed while adjusting and loading the machine.

Step 9 – Place a couple of clays in each of the carousel columns, for the purpose of testing the clay flight and trajectory.



CLAY TARGET MACHINES

ADJUSTING THE ELEVATION OF THE MACHINE

Step 10 – Adjust the machine elevation by loosening $\frac{3}{4}$ " nut on the side of the machine as shown below, and move the machine up or down. **Once the correct angle is achieved, RETIGHTEN the nut.**

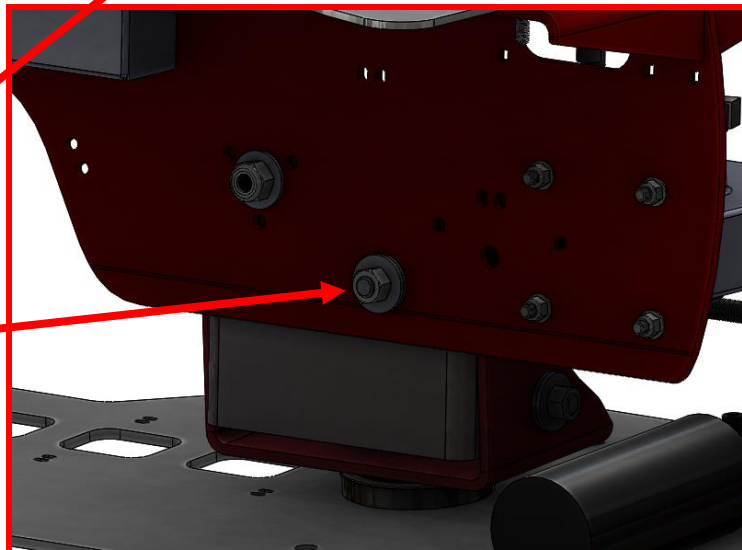
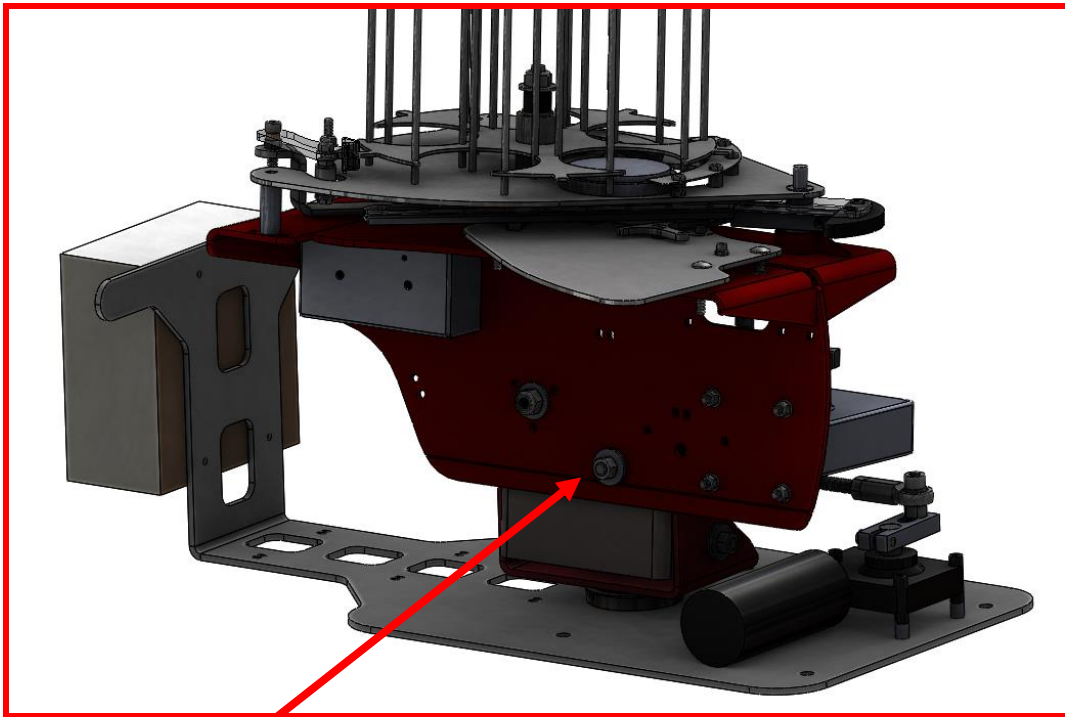

**LOOSEN/TIGHTEN
THIS NUT TO
MAKE YOUR
ELEVATION
ADJUSTMENTS.**



CLAY TARGET MACHINES

ADJUSTING THE TILT/ANGLE OF THE MACHINE

Step 11 – Adjust the machines tilt by loosening the lever on the rear side (Photo #1) of the upright of the machine as shown below. Tilt the machine to the desired angle by adjusting the turnbuckle. (Photo #2) Adding tilt allows the machine to throw a flat target with no curl. Once the correct tilt has been achieved

RETIGHTEN ALL (4) NUTS TO KEEP THE MACHINE FROM SHIFTING OVER TIME.

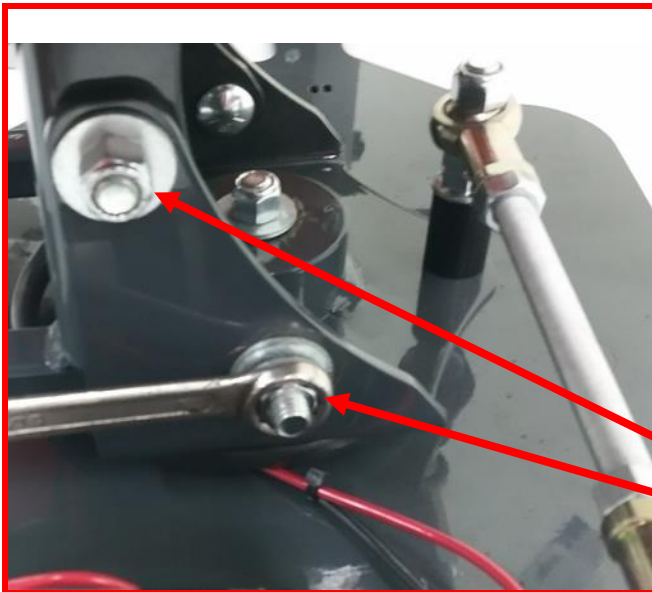

1.

**LOOSEN/TIGHTEN
THESE NUTS TO
MAKE YOUR TILT
ADJUSTMENTS.**

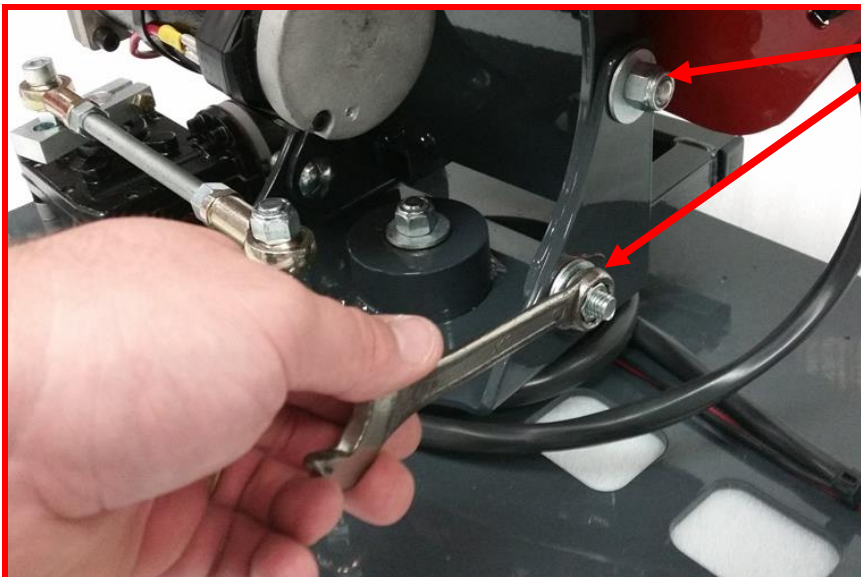

2.



CLAY TARGET MACHINES

ADJUSTING THE ROTATION ANGLE

Step 12 –To center the field, nudge the rotation motor so that the clamp block shown below is pointing straight out to the left side of the machine when viewed from behind. Notice the photo is shown to the right as picture is from front of the machine. This position should have your machine perpendicular to the house window thus throwing the clay straight down the center of the field.

Step 13 – Next, if the clay is not traveling straight away down the center of the field, simply loosen the nuts on the threaded rod and either extend or shorten the threaded rod to get the machine to fire the clay on center. Extending the threaded rod will move the field to the right and shortening the rod will move the field to the left when viewed from behind. In order to adjust the threaded rod, you will have to remove one end of the crank assembly to wind or unwind the rod end for this adjustment.

RETIGHTEN THE NUTS SECURELY ON THE THREADED ROD TO HOLD THE CORRECT ADJUSTMENT!!!

Step 14 – Check the flight angle of the clay. To open up the flight angle, loosen the 3/8" Allen bolt and slide it out on the slot of the clamp block. Retighten the bolt securely and test fire. Sliding the bolt in on the slot will reduce the angle flight of the clay.

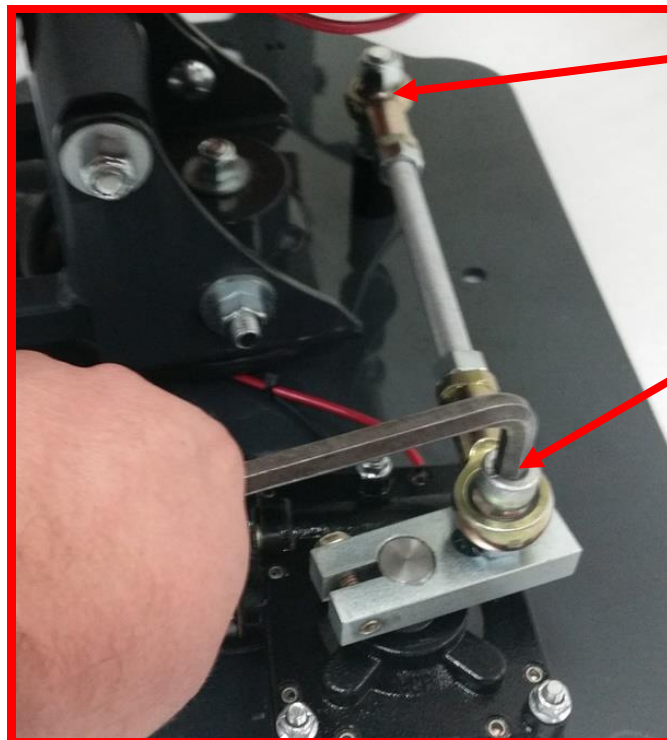

REMOVE THIS END
TO ADJUST THE
THREADED ROD
LENGTH IF
NECESSARY!

TO ADJUST FLIGHT
ANGLE, SLIDE THIS
BOLT IN THE SLOT
IN THE CLAMP
BLOCK!



CLAY TARGET MACHINES

Step 15 – You can adjust the distance that the clay is thrown by extending the spring. This is achieved by winding tension on or off the main spring using a 3/4" wrench or the optional 3/4" extended socket which can be attached to an impact drive. This should be done with the machine in the disarmed/safe condition for small adjustments. **AFTER ADJUSTING THE MAIN SPRING FOR THE CORRECT THROWING DISTANCE, THE NUTS ON THE SPRING STUD MUST BE TIGHTENED SECURELY AGAINST EACH OTHER.**



1. LOOSEN NUT

2. TIGHTEN OR LOOSEN NUT
TO DESIRED SPRING TENSION

**3. RETIGHTEN BOTH
NUTS SECURELY
WHEN DONE!!!**

Step 16 – The pull cord or optional radio release can now be connected to the machine.

Step 17 – Now that the machine is set to the correct ATA standards, carefully fully load the carousel with clays, removing any clays that show signs of damage. Load clays as evenly as possible and do not over load.

Step 18 – The machine is now ready for use by pressing the ARM/OFF/DISARM toggle switch, down to the "ARM" position.



CLAY TARGET MACHINES

Step 19 – Press the fire button on the pull cord or radio release. This will cause the machine to fire a clay target and then reset to the firing position. Pressing the fire button again will do the same as above. Pressing and holding the fire button will continuously fire clays continuously. Your machine is now operating smoothly and ready for use. **It is critical that you never load or make adjustment to the machine unless it is disarmed and the power disconnected.** While in storage, the machine must be left in the disarmed state and the power/battery disconnected. Any spring tension does not need to be released.

Thanks for choosing MEC! Every machine is hand set and tested prior to leaving our shop to ensure quality. We take pride in our products, so you can have a better experience in the field. Your patronage is very much appreciated!

For any questions regarding setup or use of any MEC Clay Target Machines, please call our toll-free number listed below, or visit us on the web to watch our setup and demonstration videos.

MEC Clay Target Machines
800 Horicon Street, Suite 1
Mayville, WI 53050 USA
920-387-6005
1-800-797-4632

www.mecshootingsports.com

To receive our monthly newsletter, go to our website, select the “Shooting Sports Lifestyle” tab and click “Join Us”.

Follow us on Facebook, Twitter, and Linked In @ MEC Shooting Sports, and on Instagram @Mecshootingsports.official to see the latest news from MEC.

For all ATA rules and guidelines please see the link below.
https://www.shootata.com/Portals/0/pdf/ata_rulebook_web.pdf



CLAY TARGET MACHINES

CORRECT POSITION OF MACHINE BASE IN TRAP HOUSE

